

VERTIGO GELATO



KEY FEATURES

- High power refrigeration system
- Semi hermetic threephase compressor
- Automatic reverse cycle defrost
- Double row of containers with storage chrome finishing
- Chrome finishing
- Tempered glass with safety tilt-down opening
- Automatic anti-fog system

FINISHING: WOODS / LAMINATES / OTHERS FINISHING

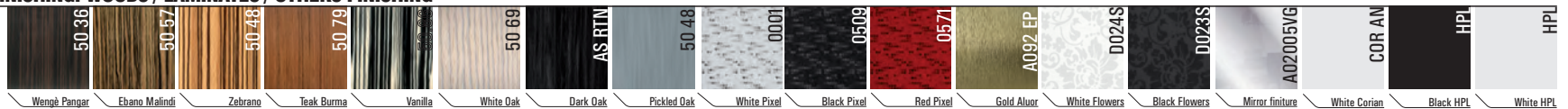

COLORS



FEATURES



Flexibility, Elegance and technology. Available in three different heights: VERTIGO 1 - total height cm117 – particularly suited for ice cream. VERTIGO 2 - total height cm 136 – the best solution for convenience store with diversified food offer. VERTIGO 3 - total height cm 150 - with three shelves fully illuminated. Enriched with extra shiny profiles which combined with the latest generation of LED lighting exalt the displayed products CIAM has at heart the safety of its customers and develops technical solutions to protect the health of the users of its products. Further configuration available: dry hot, bain-maire, gelato, bread and more.

VERTIGO

CIAM
REFRIGERATION DESIGN

VERTIGO GELATO

SECTIONS AND MODELS

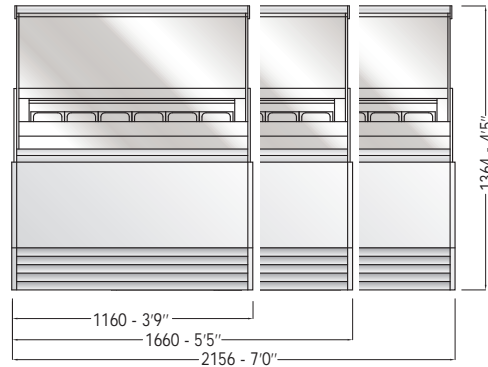
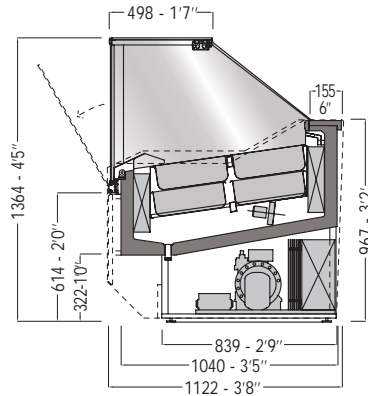

VERTIGO 2 - GELATO

TECHNICAL FEATURE		VERSIONS					
		1110	1610	2106	2106 Double Temp.	30° Open Corner	30° Closed Corner
External dimensions (L-D-H)	inches mm	43 ² / ₃ "- 44 ¹ / ₈ "- 53 ² / ₃ " 1160-1122-1364	65 ¹ / ₂ "- 44 ¹ / ₈ "- 53 ² / ₃ " 1660-1122-1364	84 ⁷ / ₈ "- 44 ¹ / ₈ "- 53 ² / ₃ " 2156-1122-1364	84 ⁷ / ₈ "- 44 ¹ / ₈ "- 53 ² / ₃ " 2156-1122-1364	62"- 44 ¹ / ₈ "- 53 ² / ₃ " 1574-1122-1364	62"- 44 ¹ / ₈ "- 53 ² / ₃ " 1574-1122-1364
Crated dimensions (L-D-H)	inches mm	52" - 52" - 63 ³ / ₄ " 1320-1320-1620	71 ⁵ / ₈ "- 52" - 63 ³ / ₄ " 1820-1320-1620	91 ¹ / ₂ "- 52" - 63 ³ / ₄ " 2320-1320-1620	91 ¹ / ₂ "- 52" - 63 ³ / ₄ " 2320-1320-1620	70 ⁷ / ₈ "- 52" - 63 ³ / ₄ " 1800-1320-1620	70 ⁷ / ₈ "- 52" - 63 ³ / ₄ " 1800-1320-1620
Pans layout - 5,2 Lt mm. 360x165x120h 14 1/8" - 6 1/2" - 4 3/4"	flavors nr. / configuration	12	18	24	24 (12+12)	12	12
Pans layout - 5,2 Lt mm. 360x250x80h 14 1/8" - 10" - 3 1/8"	flavors nr. / configuration	8	12	16	16 (8+8)	8	8
Refrigeration	Type	Fan Ventilated	Fan Ventilated	Fan Ventilated	Fan Ventilated	Fan Ventilated	Fan Ventilated
Refrigerated display area	Type	Deck	Deck	Deck	Deck	Deck	Deck
Operating temperature	°C / °F	-18 /-0.4	-18 /-0.4	-18 /-0.4	-18 /-0.4	-18 /-0.4	-18 /-0.4
Compressor	nr. / Type	1 / semihermetic	1 / semihermetic	1 / semihermetic	2 / semihermetic	1 / semihermetic	1 / semihermetic
Cooling power *	(W)	800	1130	1440	800+800	1030	1030
Electric supply	(V/ph/Hz)	400/3/50 +N (UE) 230-208/3/60 (USA)	400/3/50 +N (UE) 230-208/3/60 (USA)	400/3/50 +N (UE) 230-208/3/60 (USA)	400/3/50 +N (UE) 230-208/3/60 (USA)	400/3/50 +N (UE) 230-208/3/60 (USA)	400/3/50 +N (UE) 230-208/3/60 (USA)
Power consumption	(W/A)	1950/5,2	3030/8,4	3620/9,4	3700/9,5	2820/7,2	2780/6,9
Defrost	Mode / type	reverse cycle	reverse cycle	reverse cycle	reverse cycle	reverse cycle	reverse cycle
Climatic class	N°/°C(F°)/H.R.	4+ /35 (95)/70%	4+ /35 (95)/70%	4+ /35 (95)/70%	4+ /35 (95)/70%	4+ /35 (95)/70%	4+ /35 (95)/70%
Refrigerant Gas	Type	R452A	R452A	R452A	R452A	R452A	R452A
Net weight	Kg / Lb	255 / 562	327 / 720	410 / 903	415 / 914	295 / 650	295 / 650
Crated weight	Kg / Lb	365 / 804	477 / 1051	610 / 1344	615 / 1355	455 / 981	455 / 981

STANDARD FEATURE

- Chrome finishing
- Semi-hermetic compressor
- Anti-fog system
- Reverse cycle defrost
- Electronic control board

OPTIONAL

- LED light
- Castors
- Remote condensing unit
- S/s containers

* At -36°C of expansion

The company reserves the right to make modifications to the products without prior notice.

CIAM s.p.a. | Viale dei Pini 9 | 06081 | Petignano di Assisi | PG - Italy | Tel: 0039 07580161
web: www.ciamweb.it | mail: info@ciamgroup.it

2017 / v1.0



CIAM
REFRIGERATION DESIGN

VERTIGO