

SPACE PASTRY



COLORS



FEATURES



KEY FEATURES

- Refrigeration also in the first shelf
- Chrome finishing
- Fluorescent lighting on each shelf
- Automatic electric defrost
- Electronic control board

SPACE

SPACE represents a real icon of the Italian Style expressed by CIAM. Its design is simply perfect down to the smallest detail. Two different heights: SPACE 2 (height cm134) and SPACE 3 (height cm150). Special prestige finishes such as chrome profiles and extra shiny steel structure (Optionals), which combine with the latest generation of LED lighting, to exalt the displayed products. Easy and Safe System Glass front opening system: front glass can be opened upright with a particular system of gas pistons that allow of blocking the glass in any position to guarantee total safety. The ceilings' layout is designed to ensure a perfectly uniform lighting.

CIAM
REFRIGERATION DESIGN

SPACE PASTRY

SECTIONS AND MODELS

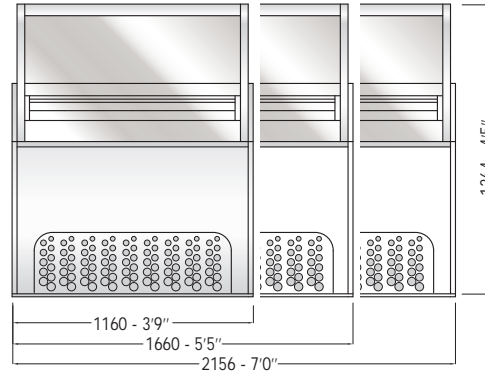
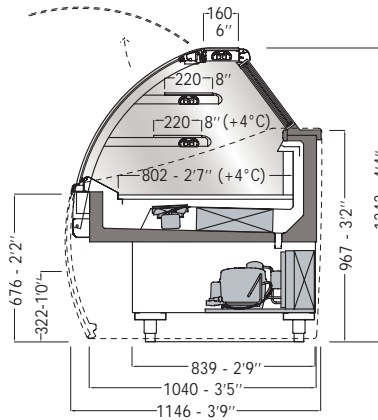

SPACE 2 - TOTALLY REFRIGERATED

TECHNICAL FEATURE		VERSIONS		
		1110	1610	2106
External dimensions (L-D-H)	inches mm	45 2/3" - 45 1/8" - 52 7/8" 1160 - 1146 - 1343	65 1/3" - 45 1/8" - 52 7/8" 1660 - 1146 - 1343	88 7/8" - 45 1/8" - 52 7/8" 2156 - 1146 - 1343
Crated dimensions (L-D-H)	inches mm	53 1/8" - 53 1/8" - 63" 1350 - 1350 - 1600	72 7/8" - 53 1/8" - 63" 1850 - 1350 - 1600	92 1/2" - 53 1/8" - 63" 2350 - 1350 - 1600
Refrigeration	Type	Fan Ventilated	Fan Ventilated	Fan Ventilated
Refrigerated display area	Type	Deck / Shelves	Deck / Shelves	Deck / Shelves
Operating temperature	°C / °F	+4 / 39.2	+4 / 39.2	+4 / 39.2
Compressor	nr. / Type	1 / hermetic	1 / hermetic	1 / hermetic
Cooling power *	(W)	990	1240	1550
Electric supply	(V/ph/Hz)	230/1/50 (UE) 120/1/60 (USA)	230/1/50 (UE) 120/1/60 (USA)	230/1/50 (UE) 120/1/60 (USA)
Power consumption	(W/A)	1270/8,7	1575/8,5	1790/10,0
Defrost	Mode / type	electric	electric	electric
Climatic class	N°/°C(F°)/H.R.	4+/35 (95)/70%	4+/35 (95)/70%	4+/35 (95)/70%
Refrigerant Gas	Type	R452A	R452A	R452A
Net weight	Kg / Lb	210 / 284	284 / 626	358 / 789
Crated weight	Kg / Lb	320 / 705	434 / 956	548 / 1208

STANDARD FEATURE

- Refrigeration in the first shelf
- Fluorescent light on each shelf
- Automatic electric defrost

OPTIONAL

- Led light
- Castors
- Remote condensing unit
- Condensate water tray whit electric evaporation

* At -10°C of expansion

The company reserves the right to make modifications to the products without prior notice.

CIAM s.p.a. | Viale dei Pini 9 | 06081 | Petignano di Assisi | PG - Italy | Tel: 0039 07580161
web: www.ciamweb.it | mail: info@ciamgroup.it

2017 / v1.0

SPACE



CIAM
REFRIGERATION DESIGN