

# SPACE ICE CREAM



## COLORS

RAL	SILVER	PANNA	CHOCIO	AZZURRO	LIMONE	LIME	AMARENA	PESCA
RAL	SILVER	RAL 8010	RAL 8014	PANTONE 285	PANTONE 384	PANTONE 383	PANTONE 233	PANTONE 165

## FEATURES



## KEY FEATURES

- High power refrigeration system
- Automatic reverse cycle defrost
- Semi-hermetic three-phase compressor
- Double row of containers with storage chrome finishing
- Automatic antifog system

# SPACE

SPACE represents a real icon of the Italian Style expressed by CIAM. Its design is simply perfect down to the smallest detail. Two different heights: SPACE 2 (height cm134) and SPACE 3 (height cm150). Special prestige finishes such as chrome profiles and extra shiny steel structure (Optionals), which combine with the latest generation of LED lighting, to exalt the displayed products. Easy and Safe System Glass front opening system: front glass can be opened upright with a particular system of gas pistons that allow of blocking the glass in any position to guarantee total safety. The ceilings' layout is designed to ensure a perfectly uniform lighting.

**CIAM**  
REFRIGERATION DESIGN

# SPACE ICE CREAM

## SECTIONS AND MODELS

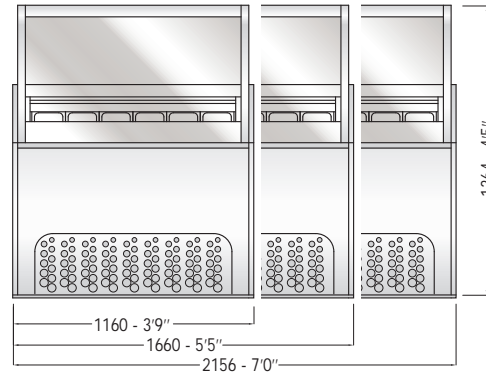
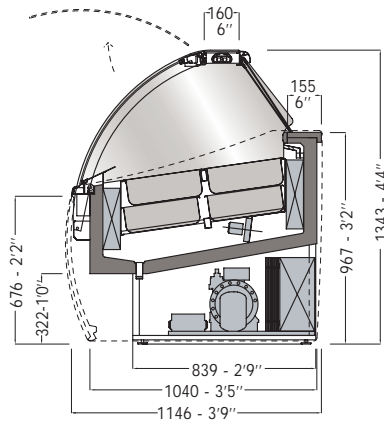

### SPACE 2 - ICE-CREAM

TECHNICAL FEATURE		VERSIONS						
		1110	1610	2106	2106 Double Temp.	30° Open Corner	30° Closed Corner	
External dimensions (L-D-H)	inches mm	45 7/8" - 45 1/8" - 52 7/8" 1160-1146-1343	65 1/3" - 45 1/8" - 52 7/8" 1660-1146-1343	88 7/8" - 45 1/8" - 52 7/8" 2156-1146-1343	88 7/8" - 45 1/8" - 52 7/8" 2156-1146-1343	62" - 45 1/8" - 52 7/8" 1574-1146-1343	62" - 45 1/8" - 52 7/8" 1574-1146-1343	
Crated dimensions (L-D-H)	inches mm	53 1/8" - 53 1/8" - 63" 1350-1350-1600	72 7/8" - 53 1/8" - 63" 1850-1350-1600	92 1/2" - 53 1/8" - 63" 2350-1350-1600	92 1/2" - 53 1/8" - 63" 2350-1350-1600	70 7/8" - 56" - 63" 1800-1420-1600	70 7/8" - 56" - 63" 1800-1420-1600	
Pans layout - 5,2 Lt mm.360x165x120h 14 1/8" - 6 1/2" - 4 3/4"	flavors nr. / configuration							
Pans layout - 5,2 Lt mm.360x250x80h 14 1/8" - 10" - 3 1/8"	flavors nr. / configuration							
Refrigeration	Type	Fan Ventilated	Fan Ventilated	Fan Ventilated	Fan Ventilated	Fan Ventilated	Fan Ventilated	
Refrig. display area	Type	Deck	Deck	Deck	Deck	Deck	Deck	
Operating temp.	°C / °F	-18 /-0.4	-18 /-0.4	-18 /-0.4	-18 /-0.4	-18 /-0.4	-18 /-0.4	
Compressor	nr. / Type	1 / semihermetic	1 / semihermetic	1 / semihermetic	2 / semihermetic	1 / semihermetic	1 / semihermetic	
Cooling power *	(W)	800	1130	1440	800+800	1030	1030	
Electric supply	(V/ph/Hz)	400/3/50 +N (UE) 230-208/3/60 (USA)	400/3/50 +N (UE) 230-208/3/60 (USA)	400/3/50 +N (UE) 230-208/3/60 (USA)	400/3/50 +N (UE) 230-208/3/60 (USA)	400/3/50 +N (UE) 230-208/3/60 (USA)	400/3/50 +N (UE) 230-208/3/60 (USA)	
Power consumption	(W/A)	1950/5,2	3030/8,4	4620/9,4	4700/9,5	2820/7,2	2780/6,9	
Defrost	Mode / type	reverse cycle	reverse cycle	reverse cycle	reverse cycle	reverse cycle	reverse cycle	
Climatic class	N°/°C(°F)/H.R.	4+ /35 (95)/70%	4+ /35 (95)/70%	4+ /35 (95)/70%	4+ /35 (95)/70%	4+ /35 (95)/70%	4+ /35 (95)/70%	
Refrigerant Gas	Type	R452A	R452A	R452A	R452A	R452A	R452A	
Net weight	Kg / Lb	254 / 560	323 / 712	360 / 793	410 / 903	295 / 650	295 / 650	
Crated weight	Kg / Lb	364 / 802	473 / 1042	560 / 1234	610 / 1344	455 / 1444	455 / 1444	

### STANDARD FEATURE

- Chrome finishing
- Semi-hermetic compressor
- Pistons assisted front glass opening system
- Fluorescent light

### OPTIONAL

- Led light
- Castors
- Remote condensing unit
- S/s containers

\* At -36°C of expansion

The company reserves the right to make modifications to the products without prior notice.

CIAM s.p.a. | Viale dei Pini 9 | 06081 | Petignano di Assisi | PG - Italy | Tel: 0039 07580161  
web: [www.ciamweb.it](http://www.ciamweb.it) | mail: [info@ciamgroup.it](mailto:info@ciamgroup.it)

2017 / v1.0



**CIAM**  
REFRIGERATION DESIGN

SPACE