

PERFORMER BAN MARIE WARM



COLORS



FEATURES



KEY FEATURES

Double glazed glasses | Front glass with pistons assisted opening system | Innovative design of ceiling profile | Perfect visibility of displayed products by any side | LED lighting

PERFORMER

Under tank in zinc coated steel | adjustable S/S feet | Ecological polyurethane insulation | ventilated refrigeration | display surface in S/S BA (available also epoxy Black painted) | LED lighting | Double glazed glasses | Front glass with lift up piston assisted opening system | Plexy sliding doors or self-rolling night blind (optional) on the operator side | Digital control board

CIAM
REFRIGERATION DESIGN

PERFORMER BAIN MARIE WARM

SECTIONS AND MODELS

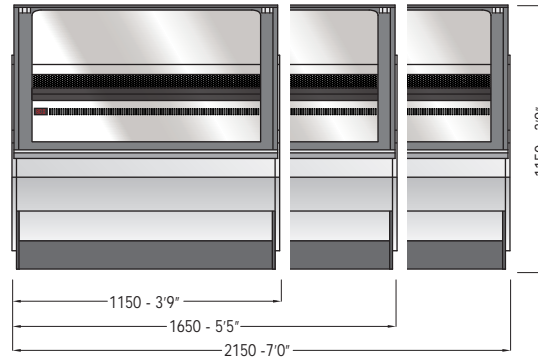
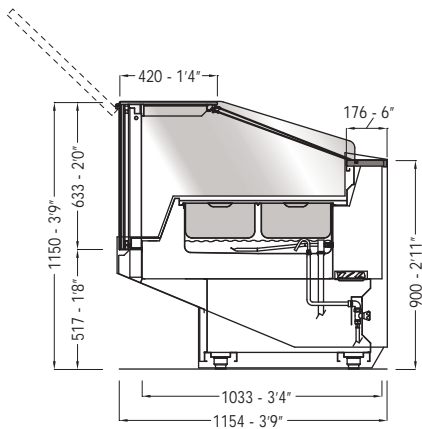

BAIN MARIE WARM

TECHNICAL FEATURE		VERSIONS		
		1150	1650	2150
External dimensions (L-D-H)	inches	45 ¼ - 45 ½ - 45 ¼	65 - 45 ½ - 45 ¼	84 ⅞ - 45 ½ - 45 ¼
	mm	1150 - 1154 - 1150	1650 - 1154 - 1150	2150 - 1154 - 1150
Crated dimensions (L-D-H)	inches	53 ⅞ - 53 ⅞ - 55 ⅞	73 ⅞ - 53 ⅞ - 55 ⅞	93 ¼ - 53 ⅞ - 55 ⅞
	mm	1370 - 1370 - 1400	1870 - 1370 - 1400	2370 - 1370 - 1400
Heating system	Type	Bain marie	Bain marie	Bain marie
Operating temperature	°C / °F	80 / 176	80 / 176	80 / 176
Electric supply	(V/ph/Hz)	230/1/50 (UE)	230/1/50 (UE)	230/1/50 (UE)
		220/1/60 (USA)	220/1/60 (USA)	220/1/60 (USA)
Power consumption	(W/A)	600/4,5	800/5,5	1200/8,0
Net weight	Kg / Lb	200/440	290/639	330/727
Crated weight	Kg / Lb	305/672	435/959	510/1124



STANDARD FEATURE

- Double glazing lift-up front glass
- Double glazing sides
- LED lighting
- Plexiglass sliding doors

OPTIONAL

- Bumper addition
- Rolling curtain
- Paper holder
- Pull-out faucet inside the tank
- Castors instead of feet
- Cutting board with knives pocket
- Scale holder
- Intermediate shelf
- Plexiglass pans holder

PERFORMER

The company reserves the right to make modifications to the products without prior notice.

CIAM s.p.a. | Viale dei Pini 9 | 06081 | Petignano di Assisi | PG - Italy | Tel: 0039 07580161
web: www.ciamweb.it | mail: info@ciamgroup.it

2017 / v1.0



CIAM
REFRIGERATION DESIGN