

TORTUGA FROZEN CAKE



KEY FEATURES

- Maxi display volume
- Equalized temperature all over the display volume
- Hinged glass doors on operator side
- LED lighting as standard
- Electronic control board
- Triple glasses

COLORS



FEATURES



TORTUGA

Full refrigerated freezer display showcase | Ventilated refrigeration (-18°C) | Display structure completely realized in triple glasses with self-closing doors on the operator side | N° 3 refrigerated shelves

CIAM
REFRIGERATION DESIGN

TORTUGA FROZEN CAKE

SECTIONS AND MODELS

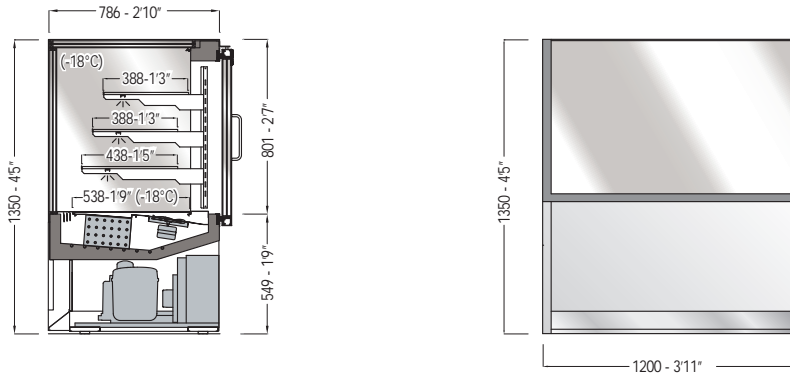

TORTUGA - FROZEN CAKE

TECHNICAL FEATURE		TORTUGA - FROZEN CAKE
		1200
External dimensions (L-D-H)	inches / mm	47 ³ / ₈ " - 31" - 53 ¹ / ₈ " 1204-786-1350
Crated dimensions (L-D-H)	inches / mm	57 ¹ / ₂ " - 39 ³ / ₈ " - 63" 1460-1000-1600
Refrigeration	Type	Ventilated
Refrig.display area	Type	Deck / Shelves
Operating temp.	°C / °F	-18 / -0.4
Compressor	nr./Type	2 / hermetic
Cooling power *	(W)	950
Electric supply	(V/ph/Hz)	230/1/50 (UE) - 220/1/60 (USA)
Power consumption	(W/A)	2300/13
Defrost	Mode / type	automatic / reverse cycle
Climatic class	N°/°C (F°) /H.R. Type	3/25 (77)/60%
Refrigerant Gas	Type	R452A
Net weight	Kg / Lb	250 / 550
Crated weight	Kg / Lb	340 / 749



STANDARD FEATURE

- Ventilated refrigeration
- Full volume temperature equalized
- LED Lighting system
- Triple glazed walls
- Triple glazed doors
- Electronic temperature control
- Automatic evaporation system of condensate water
- Double glazing hinged doors

OPTIONAL

- Castors
- Remote condensing unit

TORTUGA

* At -37°C of expansion

The company reserves the right to make modifications to the products without prior notice.

CIAM s.p.a. | Viale dei Pini 9 | 06081 | Petignano di Assisi | PG - Italy | Tel: 0039 07580161
web: www.ciamweb.it | mail: info@ciamgroup.it

2017 / v1.0



CIAM
REFRIGERATION DESIGN