

6040 G1 CUBO PASTRY / PRALINE



COLORS



FINISHING



FEATURES



DISPLAY TANK

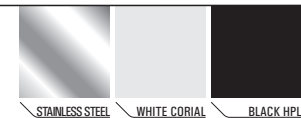

6040

The new G1 upper glass structure is the solution preferred by architects and designers, for its elegance, linearity and absolute transparency. With double opening system (patent pending) - Sliding on the operator side, and lifting up on the customer side - G1 is extremely practical and appreciated. The whole glass structure works as a glass table and helps the customer service. LED lighting system as standard.

CIAM
REFRIGERATION DESIGN

6040 G1 CUBO PASTRY/PRALINE

SECTIONS AND MODELS

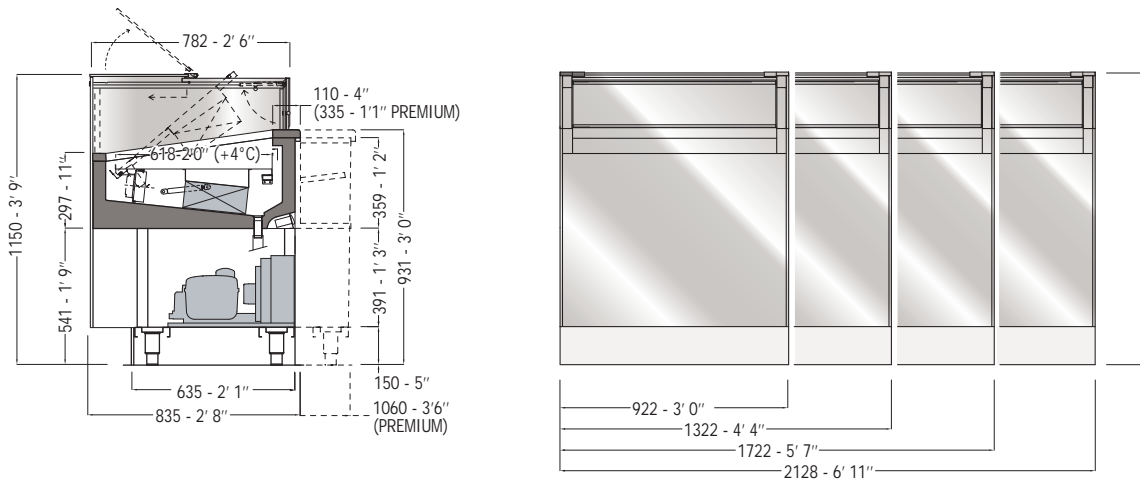

6040 G1 CUBO - PASTRY



TECHNICAL FEATURE	VERSIONS	VERSIONS			
		900	1300	1700	2106
External dimensions (L-D-H)	inches mm	36 1/4"- 32 3/4"- 45 1/4" 922 - 835 - 1150	52"- 32 3/4"- 45 1/4" 1322 - 835 - 1150	67 3/4"- 32 3/4"- 45 1/4" 1722 - 835 - 1150	83 3/4"- 32 3/4"- 45 1/4" 2128 - 835 - 1150
Crated dimensions (L-D-H)	inches mm	43 1/3"- 39 3/8"- 55 1/8" 1100-1000-1400	59"- 39 3/8"- 55 1/8" 1500-1000-1400	74 7/8"- 39 3/8"- 55 1/8" 1900-1000-1400	90 1/2"- 39 3/8"- 55 1/8" 2300-1000-1400
Refrigeration	Type	Fan Ventilated	Fan Ventilated	Fan Ventilated	Fan Ventilated
Refrigerated display area	Type	Deck	Deck	Deck	Deck
Operating temperature	°C / °F	4 / 39.2	4 / 39.2	4 / 39.2	4 / 39.2
Compressor	nr. / Type	1 / hermetic	1 / hermetic	1 / hermetic	1 / hermetic
Cooling power *	(W)	380	550	690	850
Electric supply	(V/ph/Hz)	230/1/50 (UE) 120/1/60 (USA)	230/1/50 (UE) 120/1/60 (USA)	230/1/50 (UE) 120/1/60 (USA)	230/1/50 (UE) 120/1/60 (USA)
Power consumption	(W/A)	565/3,5	680/4,0	885/4,5	1100/6,0
Defrost	Mode / type	automatic	automatic	automatic	automatic
Climatic class	N°/°C (F°)/H.R.	4/30 (86)/55%	4/30 (86)/55%	4/30 (86)/55%	4/30 (86)/55%
Refrigerant Gas	Type	R452A	R452A	R452A	R452A
Net weight	Kg / Lb	104 / 229	127 / 279	157 / 346	172 / 379
Crated weight	Kg / Lb	164 / 361	207 / 456	257 / 566	297 / 654

STANDARD FEATURE

- LED lighting system
- Extra clear glass
- Lift-up mechanism for the display plate and the evaporator in order to grant easier cleaning
- Patented upper sliding glass system

OPTIONAL

- S/s esposition step
- S/s dry hot plate
- Working top perimeter (brushed s/s, corian, black HPL, granite)
- Remote condensing unit
- Wheels kit
- PREMIUM version

* At -10°C of expansion

The company reserves the right to make modifications to the products without prior notice.

CIAM s.p.a. | Viale dei Pini 9 | 06081 | Petignano di Assisi | PG - Italy | Tel: 0039 07580161
web: www.ciamweb.it | mail: info@ciamgroup.it

2017 / v1.0



CIAM
REFRIGERATION DESIGN

6040