

MYA NARROW ICE CREAM



KEY FEATURES

- **Performances:** forced air refrigeration system
- **Visibility:** extraordinary enhancement of displayed products
- **Practicality:** pistons assisted front glass opening system
- **Customizable:** great possibility to customize front side panels
- **Temperature controlled:** -18°C / +4°C (-0 4°F / +41°F)
- **Double glazing:** front, top and side glasses
- **Energy Saving:** double LED lighting as standard
- **Multiplexing:** combine easily Mya, Mya Narrow, Mya Combi, Mya Plus together on a continuous solution

COLORS



FINISHING



FEATURES



MYA COLLECTION: CIAM's spearhead production. It is the perfect synthesis of PERFORMANCE, ERGONOMICS, ENERGY SAVING, DISPLAYED PRODUCT VISIBILITY. High performance maintains the product even in the worst ambient condition. You will be surprised by MYA's performance. MYA cabinets are tested in class 4+ (35°C / 70% HR): even in the worst ambient condition, MYA cabinets can ensure a perfect food preservation. All the upper glass structure of MYA's cabinets is realized in double glazing, to avoid the fog even in high relative humidity conditions.

MYA

CIAM
REFRIGERATION DESIGN

MYA NARROW ICE CREAM

SECTIONS AND MODELS

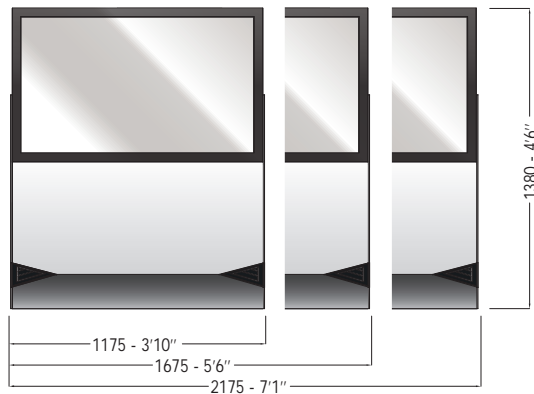
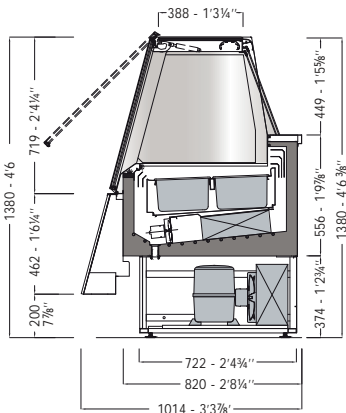

MYA NARROW - ICE CREAM

TECHNICAL FEATURE		VERSIONS			
		1150	1650	2150	2150 Double Temp.
External dimensions (L-D-H)	inches mm	46 1/4" - 39 7/8" - 54 1/3" 1175 - 1014 - 1380	65 1/2" - 39 7/8" - 54 1/3" 1675 - 1014 - 1380	85 2/3" - 39 7/8" - 54 1/3" 2175 - 1014 - 1380	85 2/3" - 39 7/8" - 54 1/3" 2175 - 1014 - 1380
Crated dimensions (L-D-H)	inches mm	52 3/8" - 47 1/4" - 63" 1330-1200-1600	72" - 47 1/4" - 63" 1830-1200-1600	91 3/4" - 47 1/4" - 63" 2330-1200-1600	91 3/4" - 47 1/4" - 63" 2380-1200-1600
Pans layout 4,2 Lt / mm. 258x165x150h 10 1/8" - 6 1/2" - 5 7/8"	flavors nr. / configuration	12	18	24	24 (12+12)
Pans layout 6,0 Lt / mm. 530x162x100h 20 7/8" - 6 3/8" - 3 7/8"	flavors nr. / configuration	6	9	12	12 (6+6)
Refrigeration	Type	Fan Ventilated	Fan Ventilated	Fan Ventilated	Fan Ventilated
Refrigerated display area	Type	Deck	Deck	Deck	Deck
Operating temperature	°C / °F	-18 /-0.4	-18 /-0.4	-18 /-0.4	-18 /-0.4
Compressor	nr. / Type	1 / hermetic	1 / hermetic	2 / hermetic	2 / hermetic
Cooling power *	(W)	630	860	1080	550+550
Electric supply	(V/ph/Hz)	230/1/50 (UE) 220/1/60 (USA)	230/1/50 (UE) 220/1/60 (USA)	230/1/50 (UE) 220/1/60 (USA)	230/1/50 (UE) 220/1/60 (USA)
Power consumption	(W/A)	1700/9,0	2200/12,0	3500/16,0	2200/12,0
Defrost	Mode / type	reverse cycle	reverse cycle	reverse cycle	reverse cycle
Climatic class	N°°C(F°)/H.R.	4+/35 (95)/70%	4+/35 (95)/70%	4+/35 (95)/70%	4+/35 (95)/70%
Refrigerant Gas	Type	R452A	R452A	R452A	R452A
Net weight	Kg - Lb	210 / 462	278 / 612	320 / 705	340 / 749
Crated weight	Kg - Lb	305 / 672	408 / 899	480 / 1058	500 / 1102

* At -33°C of expansion

The company reserves the right to make modifications to the products without prior notice.

CIAM s.p.a. | Viale dei Pini 9 | 06081 | Petignano di Assisi | PG - Italy | Tel: 0039 07580161
web: www.ciamweb.it | mail: info@ciamgroup.it

2017 / v1.0

MYA



CIAM
REFRIGERATION DESIGN