

EKL 1264 R

PROOFER WITH WHEELS AND HUMIDIFICATION

A reliable proofer with generous capacity featuring a manual button used to generate humidity and a condensate drip tray. The castors, fitted as standard, make the cabinet easier to move, giving you greater freedom to arrange equipment how you want and tailor rooms to your individual requirements. It features a modular design so that it goes with all electric and gas ovens from the 4,6 and 10 pan series, except those from the Touch range.

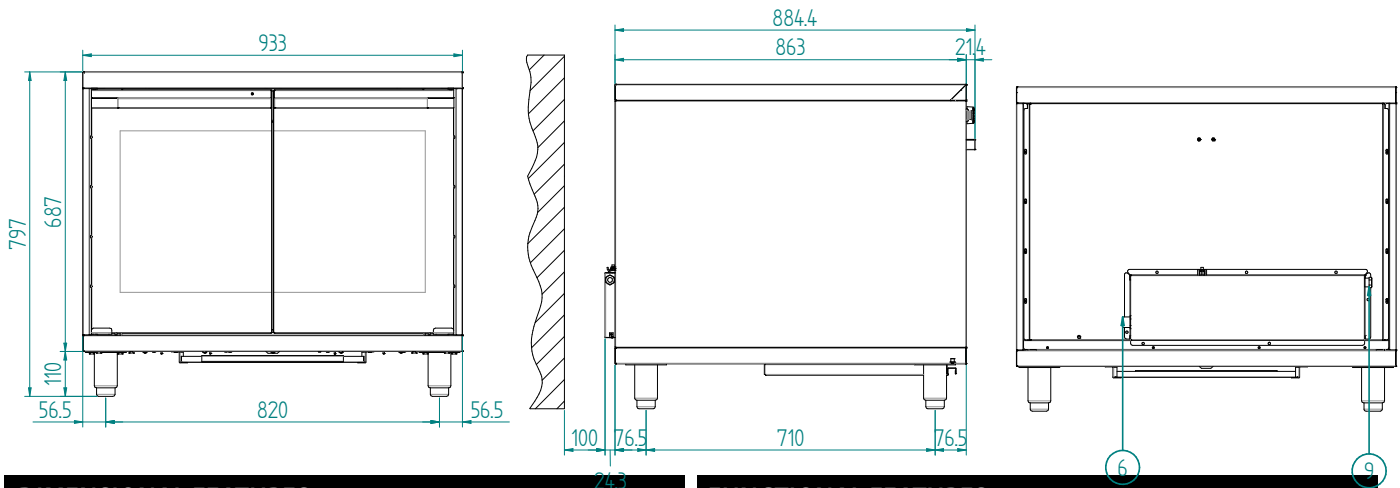

DIMENSIONAL FEATURES			
Proofer dimensions (WxDxH mm)	935	910	825
Proofer weight (kg)	59.24		
Distance between rack rails (mm)	75		

ELECTRICAL FEATURES	
Power supply (kW)	2,4
Frequency (Hz)	50/60
Voltage (Volt)	AC 220/230
N° of motors	/
Boiler	/
Protection against water	IPX4

EQUIPMENT			
Cardboard box dimensions with pallet (WxDxH mm)	1020	960	875
Lateral supports	1 right + 1 left		
Cable	Single-phase [3G 1,5] - L=1300 mm		
Removable drip box			

PLUS	
New door	
New wheels	
IPX4	

FUNCTIONAL FEATURES	
Power	Electricity
Capacity	N° 12 Trays (600x400 mm)
Type of cooking	/
Humidification	Indirect with button
Proofing chamber	AISI 430 Stainless Steel
Temperature	30 ÷ 60°C
Temperature control	Thermostat
Control panel	Electromechanical – Top side
N° of programs	/
Programmable cooking steps	/
Pre-heating temperature	/
Door	Double leaf

MODULARITY
Electric and gas ovens - 4,6 and 10 trays (except Touch line)