

EKF 464 D AL UD

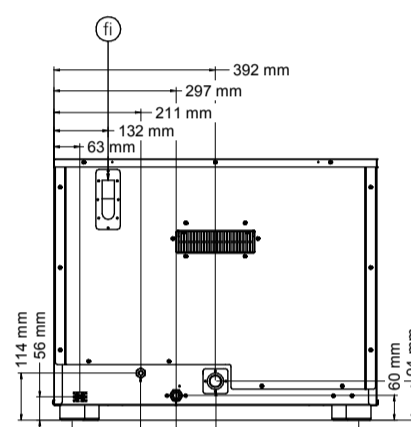

DIGITAL ELECTRIC CONVECTION OVEN WITH STEAM

A blend of all-Italian technology and quality. Cakes, sweet snacks, plain or filled croissants: with the direct steam option you really can customize how each dish is baked. You control the oven with its innovative digital control panel, which has 99 programs, allowing you to cook in 4 stages, setting the time, temperature, humidity level and core probe temperature for each.

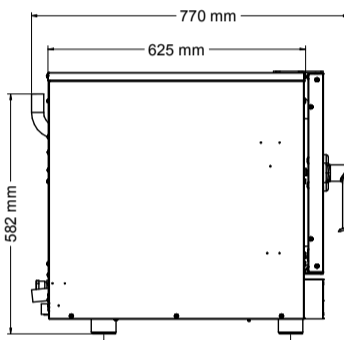
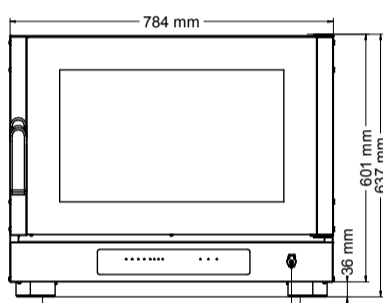

DIMENSIONAL FEATURES			
Oven dimensions (WxDxH mm)	784	770	637
Oven weight (kg)	58		
Distance between rack rails (mm)	83		

ELECTRICAL FEATURES	
Power supply (kW)	6,4
Frequency (Hz)	50/60
Voltage (Volt)	AC 380/400 2N
N° of motors	2 Bidirectional
Boiler	/
Protection against water	IPX3

EQUIPMENT			
Cardboard box dimensions with pallet (WxDxH mm)	805	830	800
Lateral supports	1 right + 1 left		
Cable	Two-Phase [4G 2,5] - L=1350 mm		
Manual washing set up			

PLUS	
Stainless steel cooking chamber	
Door with inspectionable glass	
Quick fastening of lateral supports	
Embedded gasket	
Stackable	
Forced cooling system of inner parts	
IPX 3	
Manual washing set up	
New design of cooking chamber	
CB certification	
New design of handle	

FUNCTIONAL FEATURES	
Power	Electricity
Capacity	N° 4 Trays/Grids (600x400 mm)
Type of cooking	Ventilated
Steam	Direct steam controlled by digital panel (10 levels)
Cooking chamber	AISI 304 Stainless Steel
Temperature	50 ÷ 270°C
Temperature control	Digital probe thermometer
Control panel	Digital - Lower side
N° of programs	99
Programmable cooking steps	4
Pre-heating temperature	180°C
Pre-heating function	Available only in "Program Mode"
Door	Right side opening door Ventilated Inspectionable glass

OPTIONAL	
Kit for overlapping ovens	Cod. EKKM4
Aluminium tray (600x400x20 mm)	Cod. KT9P/A
Perforated aluminium tray (600x400x20 mm)	Cod. KTF8P/A
5 Lanes perforated aluminium tray (600x400x20 mm)	Cod. KTF9P
Chromed grid (600x400 mm)	Cod. KG9P
5 Lanes AISI 304 Grid (600x400 mm)	Cod. KG5CPX
Table	Cod. EKT 411 - Cod. EKTR 411 Cod. EKTS 411 - Cod. EKTRS 411 Cod. EKT 411 D
Proofer	Cod. EKL 864 Cod. EKL 864 R
Condensation hood	Cod. EKKC4
Spray kit with support	Cod. EKKD
Air reducer	Cod. EKRPV/A
Water tank lt. 7	Cod. EKSA
Pump kit with hose and filter	Cod. KKPU
Possibility of bivalent supports	Code EKF 416 D UD EKF 416 D AL UD (with side door opening)

