

# EKF 464 AL UD

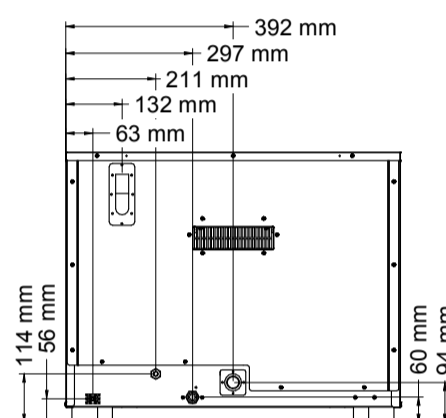

## ELECTRIC CONVECTION OVEN WITH STEAM

Handy use and quality. It bakes plain and filled croissants and is a valuable ally when you want to heat and revive the fragrance of frozen bread: its natural habitat is the small bakery or pastry business where space is invariably at a premium. Despite its compact design and foolproof use, the EKF 464 UD oven - with its direct steam option allowing you to customize each recipe based on individual baking requirements - will reward you with professional results while keeping cooking time and energy usage to a minimum.

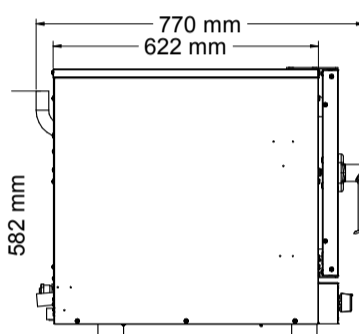
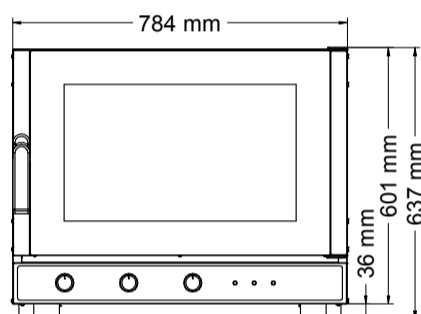

DIMENSIONAL FEATURES			
Oven dimensions (WxDxH mm)	784	752	637
Oven weight (kg)	58		
Distance between rack rails (mm)	83		

ELECTRICAL FEATURES	
Power supply (kW)	6,4
Frequency (Hz)	50/60
Voltage (Volt)	AC 380/400 2N
N° of motors	2 Bidirectional
Boiler	/
Protection against water	IPX3

EQUIPMENT			
Cardboard box dimensions with pallet (WxDxH mm)	805	830	800
Lateral supports	1 right + 1 left		
Cable	Two-Phase [4G 2,5] - L=1350 mm		
Manual washing set up			

PLUS	
Stainless steel cooking chamber	
Door with inspectionable glass	
Quick fastening of lateral supports	
Embedded gasket	
Stackable	
Forced cooling system of inner parts	
IPX 3	
Manual washing set up	
New design of cooking chamber	
CB certification	
New design of handle	

FUNCTIONAL FEATURES	
Power	Electricity
Capacity	N° 4 Trays/Grids (600x400 mm)
Type of cooking	Ventilated
Steam	Direct steam controlled by knob (5 levels)
Cooking chamber	AISI 304 Stainless Steel
Temperature	50 ÷ 300°C
Temperature control	Digital probe thermometer
Control panel	Digital - Lower side
N° of programs	/
Programmable cooking steps	/
Pre-heating temperature	/
Pre-heating function	/
Door	Right side opening door Ventilated Inspectionable glass

OPTIONAL	
Kit for overlapping ovens	Cod. EKKM4
Aluminium tray (600x400x20 mm)	Cod. KT9P/A
Perforated aluminium tray (600x400x20 mm)	Cod. KTF8P/A
5 Lanes perforated aluminium tray (600x400x20 mm)	Cod. KTF9P
Chromed grid (600x400 mm)	Cod. KG9P
5 Lanes AISI 304 Grid (600x400 mm)	Cod. KG5CPX
Table	Cod. EKT 411 - Cod. EKTR 411 Cod. EKTS 411 - Cod. EKTRS 411 Cod. EKT 411 D
Proofer	Cod. EKL 864 Cod. EKL 864 R
Condensation hood	Cod. EKKC4
Spray kit with support	Cod. EKKD
Air reducer	Cod. EKRPA/A
Water tank lt. 7	Cod. EKSA
Pump kit with hose and filter	Cod. KKPU
Possibility of bivalent supports	Code EKF 416 UD and EKF 416 AL UD (with side door opening)

